

## Auto Comfort Chair "Positive Response"

### Task Description: **Riding tractor**

Tractor drivers undergo whole body vibrations on the road and on the field.

### Comments of the employee:

- ❑ 'No comfortable sitting posture'
- ❑ 'Vibrations (seat, quality floor, hand/arm machinery...)'
- ❑ 'Opportunity to have a break or change activity'

### MSD risks:

- ❑ Posture
- ❑ Duration
- ❑ Vibrations (whole body or hand/arm)

### Exposed areas:

- ❑ Lower back

### Solutions:

- ❑ CNH – Auto Comfort Chair "Positive Response" (Sears)  
This is a semi-active "Vibration Reduction System". The movements of the tractor are continuously measured by a position sensor. A damping cylinder adapts immediately to the correct damping level.

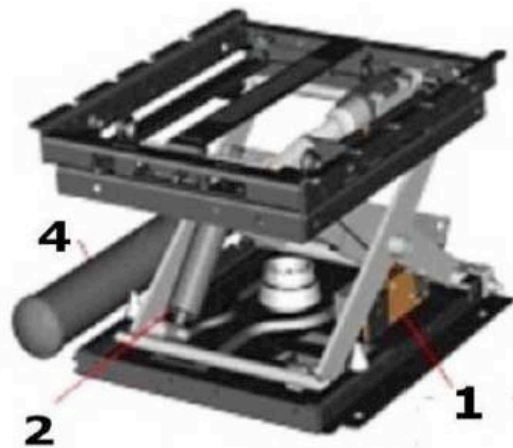
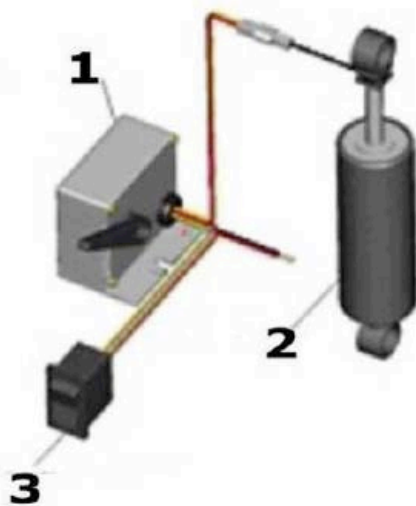

- 1: position sensor
- 2: semi-active shock damper
- 3: button to adapt comfort level
- 4: air reservoir.